



WideTEK® 36ART



## Setup Instructions English

07/2019

# Contents

<b>Revision History .....</b>	<b>5</b>
<b>Information about the Instructions and the Manufacturer .....</b>	<b>6</b>
Keep Instructions with the Scanner .....	6
Design Features in Text.....	7
Design Features in Pictures.....	8
Associated Documents .....	8
Copyright .....	8
Contact Data of the Manufacturer in Germany.....	9
Technical Support .....	9
Contact Data of the Manufacturer in the U.S. ....	9
<b>Safety.....</b>	<b>10</b>
Intended Use .....	10
Basic Safety Information .....	10
Avoiding Property Damage and Malfunctions.....	12
Responsibility of the Owner .....	12
Staff Qualifications.....	12
Design Features of Warning Notices .....	13
Formatting of Information Regarding Property Damage.....	13
<b>Description .....</b>	<b>14</b>
Purpose and Function .....	14
WideTEK® 36ART Overview .....	14
Rear View .....	15
Setup Menu Overview Screen .....	16
Rating Plate.....	17
<b>Prepare for Setup.....</b>	<b>18</b>
Connect the Power Supply .....	18
Establish the Network Connection .....	19
Connect the Optional Monitor .....	19

Switch On the Scanner .....	20
Switch Off the Scanner .....	22
<b>Perform Setup.....</b>	<b>23</b>
Change the Menu Language.....	23
Inserting and Aligning the Scan Table .....	25
Placing an Object to be Scanned on the Scan Table.....	26
Scanning and Watching the Object Move Through the Scanner.....	31
Preparing Whitebalance.....	31
Activate the Setup Menu.....	35
Perform White Balance .....	39
Assign the IP Address .....	47
Modify User Settings .....	56
Set the Time and Date .....	60
Perform Test Suite.....	65
Perform Touchscreen Test .....	68
<b>Recovery .....</b>	<b>72</b>
Hard Disk / Solid State Disk Software Failure .....	72
Recover the HD/SSD to Factory Default .....	73
Preparations to Recover an HD/SSD.....	73
Recovery Process.....	73
Recovery Process 2 - Update Scanner Firmware .....	76
Recovery Process 3 - Adjustments .....	76
<b>Maintenance.....</b>	<b>77</b>
Touchscreen .....	77
Surfaces .....	77
Repair .....	77
<b>Technical Specifications .....</b>	<b>78</b>
Scanner Specification .....	78
Electrical Specifications .....	79
Document Specification .....	79

Dimensions and Weight.....	80
Ambient Conditions .....	80

## Revision History

Date	Rev.	Name	Description of Change	Reason of Change
16.02.2018	1.0	JKN	First draft	First published version
23.07.2019	1.1	JKN	Second draft	New chapters: Recovery, Touchscreen Test

## **Information about the Instructions and the Manufacturer**

These instructions show you how to safely prepare and perform the setup for the art scanner WideTEK® 36ART-600. The WideTEK® 36ART-600 scanners are hereinafter referred to as "Scanner".

In these instructions, the start button is called "power button".

### **Keep Instructions with the Scanner**

These instructions are a part of the scanner.

- Please always store these instructions together with the scanner.
- Ensure that the instructions are available for the user.
- Enclose the instructions when you sell the scanner or transfer it in any other way.

## Design Features in Text

Many text passages in these instructions have been formatted to indicate specific elements, as illustrated below:

Normal text

BUTTONS OF THE SCREEN PAGE

"Menu names"

➤ Action steps

• Enumeration of the first level

*Cross-references*

 Tips contain additional information, such as special information to prepare for and perform the setup.

## Design Features in Pictures

Where a reference is made to elements in a legend or in the text, these are marked with a number (1).

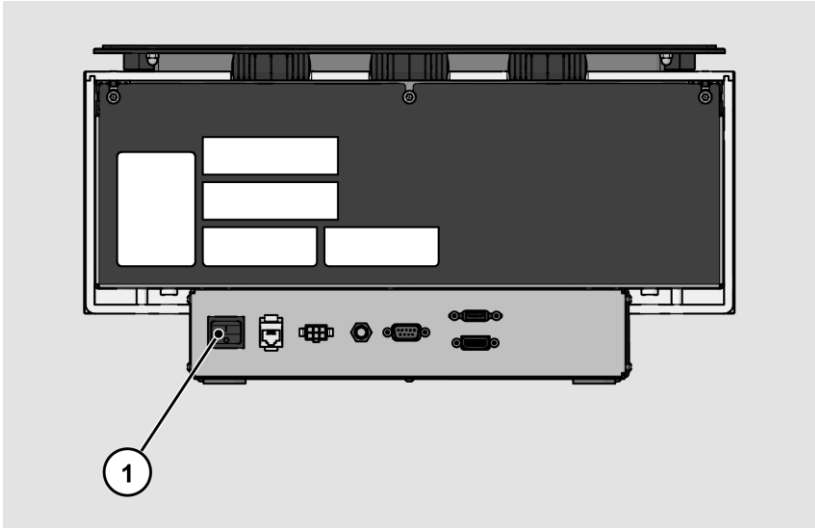

## Associated Documents

In addition to these instructions, other documents associated with the operation of the scanner include:

- Unpacking and Repacking Instructions
- Legal Information (Declarations of Conformity, FCC Declaration, Safety & EMI Certificates, RoHS etc.).

## Copyright

These instructions contains information that is subject to copyright. These instructions may not be reproduced in any form, printed, filmed, edited, copied or distributed, in whole or in part, without prior written permission from Image Access GmbH.

© Image Access GmbH 2019  
All rights reserved.



**Trademarks**

Scan2Net®, Scan2PAD®, Bookey® and WideTEK® are registered trademarks of Image Access, all other trademarks are the property of their respective owners.

**Contact Data of the Manufacturer in Germany**

Image Access GmbH  
Hatzfelderstraße 161-163  
42281 Wuppertal  
Phone: +49-202-27058-0  
E-Mail: [documentation@imageaccess.de](mailto:documentation@imageaccess.de)  
Internet address: [www.imageaccess.de](http://www.imageaccess.de)

**Technical Support**

Image Access technical support can be reached at the e-mail address:  
[support@imageaccess.de](mailto:support@imageaccess.de).

**Contact Data of the Manufacturer in the U.S.**

Image Access LP  
2511 Technology Drive, Suite 109  
Elgin  
IL 60124  
Phone: +1-224-293-2585  
E-Mail: [support@imageaccess.us](mailto:support@imageaccess.us)  
Internet address: [www.imageaccess.us](http://www.imageaccess.us)

## Safety

### Intended Use

The scanner is used for scanning fine art and other material and documents. The fine art must comply with the characteristics described in the technical specifications. The scanner is designed for use in enclosed spaces in the commercial sector.

Intended use also includes observing and following all information provided in these instructions, especially the safety instructions. Any other use is considered to be improper and will void the warranty and liability claims.

### Ambient Conditions

Ensure that the scanner is used exclusively under the following environmental conditions:

- Ambient temperature during operation: 5°C to 40°C (40° to 105°F)
  - Storage temperature: 0°C to 60°C (32° to 140°F)
  - Relative humidity: 20 to 80% (non-condensing)
  - Ambient light level between 100 and 1.000 lux
- Ensure that the scanner is not exposed to direct sunlight.

## Basic Safety Information

### Avoid Injury or Death by Electric Shock

- Never open the housing of the scanner.
- Do not expose the scanner to dripping or splashing water and do not place any vessel filled with liquid on the scanner. Penetrating liquid can damage the scanner.
- Do not insert objects through existing slots or openings into the interior of the scanner.

- Only connect the scanner with the plug of the supplied AC adapter to a professionally installed and grounded outlet.
- Do not use the AC adapter if the power supply's housing or the cable are damaged. In this case, replace the power supply with a power supply of the same type.
- Do not use the scanner if it is visibly damaged. In this case, unplug the power cord from the wall outlet. Contact Image Access technical support, see section *Technical Support* starting at page 9.

### **Avoid Burns**

- Do not cover the existing openings in the scanner housing. They serve to ventilate. Covering the openings could cause overheating.
- Do not place the scanner in front of air conditioning units, which produce high heat.

### **Avoid Fractures, Contusions and Bruises**

Incorrect installation of the cables can cause tripping.

- Lay the connecting cables so that no one can trip over them.

The scanner weighs 440 lbs. (200 kg).

- Only carry the scanner with a second person and a floor jack. Follow the "Unpacking and Repacking Instructions".
- Place the scanner only on a stable, vibration free floor.
- Make sure that the scanner is leveled, as described in the "Assembly Instructions".

## **Avoiding Property Damage and Malfunctions**

- Ensure adequate ventilation to comply with the environmental conditions.
- Do not place the scanner in the vicinity of devices that emit strong electromagnetic radiation.
- Do not lean on the scanner.
- Ensure that the thickness of the original to be scanned does not exceed the current clearance between 100 and 200 mm (4 and 8 inch.).
- Do not use any cleaning agents containing abrasive additives, solvents or acids. Use a damp microfiber cloth.
- Operate the touchscreen only with your finger. Other objects can damage the touchscreen.

## **Responsibility of the Owner**



The scanner owner must ensure that only qualified personnel carry out the setup of the scanner.

## **Staff Qualifications**



The staff that carries out the setup of the scanner must have knowledge in installing, connecting and putting computer accessories into operation.

## Design Features of Warning Notices

In these instructions, the following warning information can be found:

<b>⚠ WARNING</b>	
	Notices with the word <b>WARNING</b> warn about a dangerous situation that could lead to death or serious injuries.
<b>⚠ CAUTION</b>	
	Notices with the word <b>CAUTION</b> warn about a situation that could lead to light or medium-scale injuries.

The following symbols are used in the warnings:

Symbol	Explanation
	Danger from electrical shock
	General danger symbol

## Formatting of Information Regarding Property Damage

<b>ATTENTION!</b>	
	These notices warn of situations that can lead to property damage.

## Description

### Purpose and Function

The scanner is used for scanning fine art and other objects as well as documents of all kind. It is designed for use in enclosed spaces in the commercial sector. The originals must conform to the characteristics according to the technical data. The scanner is designed for indoor use in commercial areas.

### WideTEK® 36ART Overview

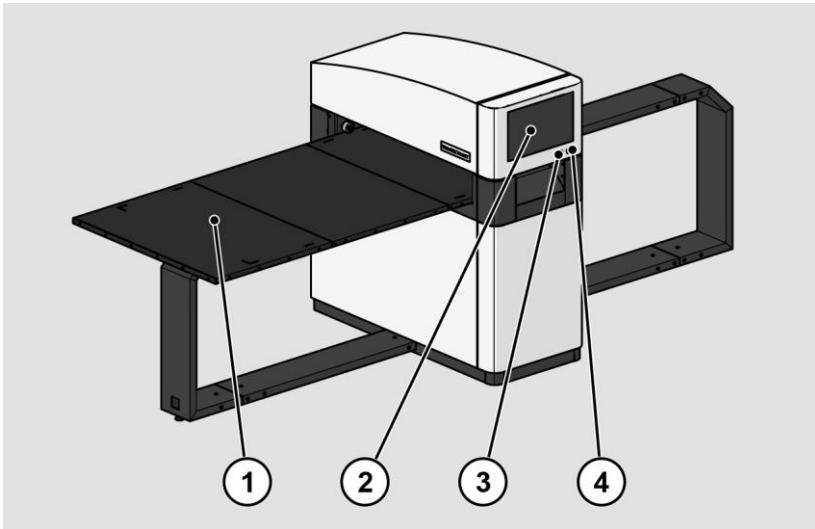

No.	Name
1	Scan table
2	Touchscreen
3	USB connector
4	Power button

## Rear View

The following diagram shows the rear view of the WideTEK® 36ART model.

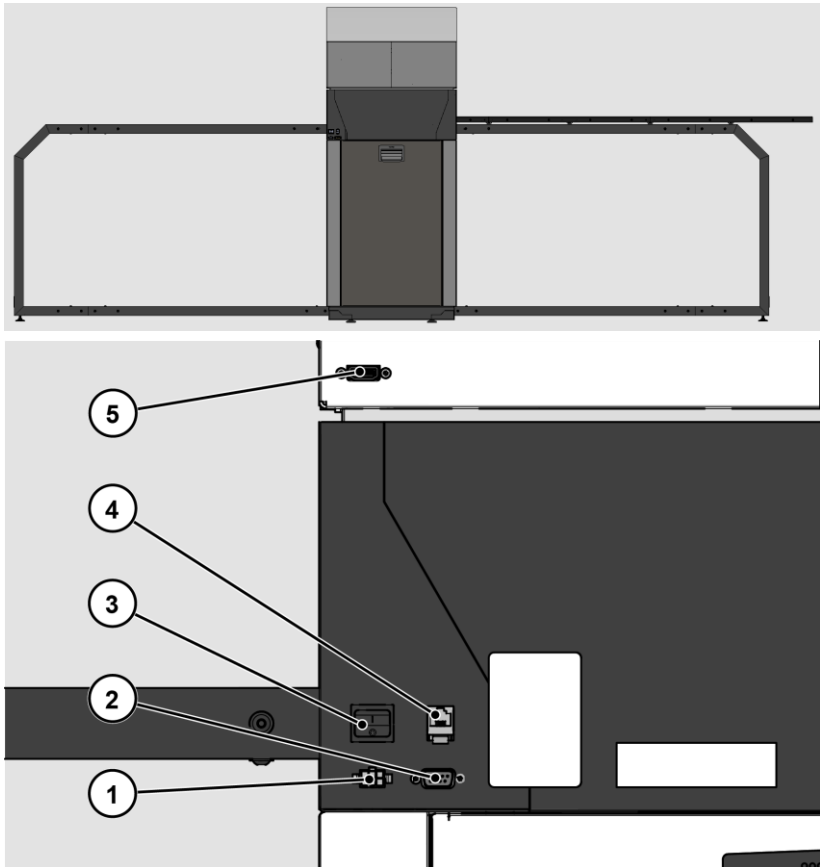

No.	Name
1	24 Vdc connector for external power supply
2	Recovery key connector
3	Main switch
4	Network connector
5	HDMI connector

## Setup Menu Overview Screen

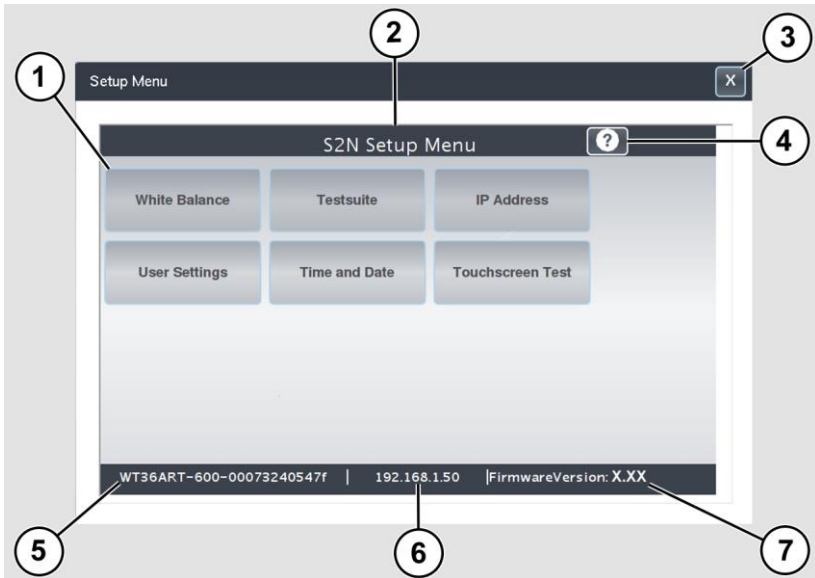

No.	Name
1	Buttons and parameters
2	Menu name
3	Button to leave the setup menu to the start screen
4	Display the online help
5	Serial number
6	IP address
7	Firmware version



## Rating Plate

The rating plate is attached to the back of the scanner.

The following figure shows the WideTEK® 36ART rating plate.

Type/品类: **Wide F. Scanner/大幅面扫描仪**

Model/型号: **WT36ART-600**

Volt/电压: **24V**  **Amperes/电流: 5A**



 This device complies with part 15 of the FCC Rules.  
 Operation is subject to the following two conditions:  
 (1) This device may not cause harmful interference  
 (2) this device must accept any interference received,  
 including interference that may cause undesired operation.



## Prepare for Setup

### Connect the Power Supply

#### **WARNING**



Risk of electric shock due to incorrect connection.

- Ensure that the power receptacle intended for the connection is properly grounded.
- Ensure that the power receptacle intended for the connection of the scanner is properly fused.

#### **CAUTION**



Incorrect laying of the connection cables can cause tripping. Fractures, contusions and bruises can be the result.

- Place the connecting cables so that no one can trip over them.

To connect the power supply, proceed as follows:

- Make sure that the main switch of the scanner is switched off (0 position).
- Use only the AC adapter and power cord supplied.
- Ensure the power cord is not damaged.
- Connect the connector from the power supply to the associated 24 Vdc connector on the back of the scanner.
- If not already done, connect the supplied power cable to the associated connector on the power supply.
- Connect the power plug of the power supply to a power receptacle of the correct voltage (100-240 Vac).

## Establish the Network Connection

### CAUTION



Incorrect laying of the connection cables can cause tripping. Fractures, contusions and bruises can be the result.

- Place the connecting cables so that no one can trip over them.

To establish the network connection, proceed as follows:

- Connect one plug of the enclosed network cable to the network connector socket on the back of the scanner.
- Connect the second plug to the network socket of an existing network.

## Connect the Optional Monitor

### CAUTION



Incorrect laying of the connection cables can cause tripping. Fractures, contusions and bruises can be the result.

- Place the connecting cables so that no one can trip over them.

To connect the optional monitor, proceed as follows:

- Connect the HDMI connector plug of the monitor to the HDMI connector socket, located on the back of the scanner.

## Switch On the Scanner

To switch on the scanner, proceed as follows:

- Press the MAIN SWITCH (1) on the back to the "I" position.

The following diagram shows the scanner model WideTEK® 36ART.

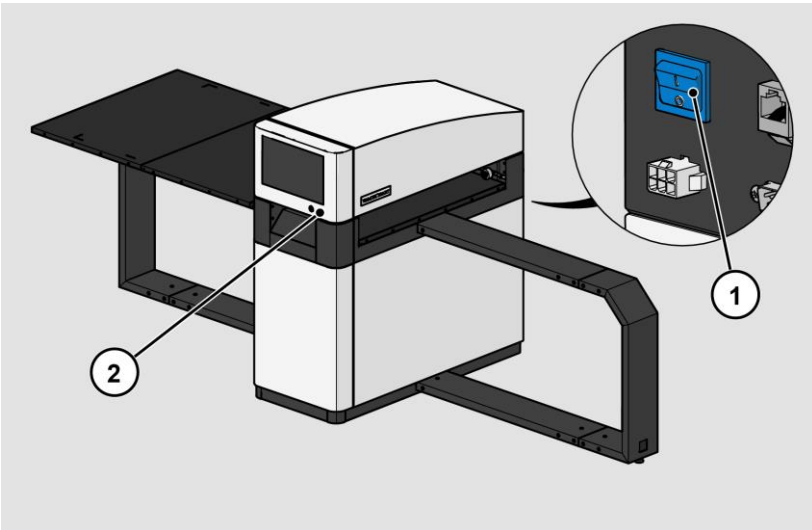

To start the scanner from standby mode, proceed as follows:

- Touch the green illuminated power button (2).

The power button lights up in blue.

The scanner performs a system test.

After a short wait, the "ScanWizard Start screen" is displayed in English.



## Switch Off the Scanner

To switch the scanner to standby mode after performing the setup, proceed as follows:

- Touch the blue illuminated power button (2) and confirm the action in the dialog on the touchscreen.

The scanner shuts down. This process can take up to 40 seconds.

The power button lights up green. The scanner is in standby mode.

To switch off the scanner for longer periods, proceed as follows:

- Make sure that the scanner is in standby mode.

The power button is illuminated in green.

- Press the MAIN SWITCH (1) in the "0" position.

The following diagram shows the scanner model WideTEK® 36ART.

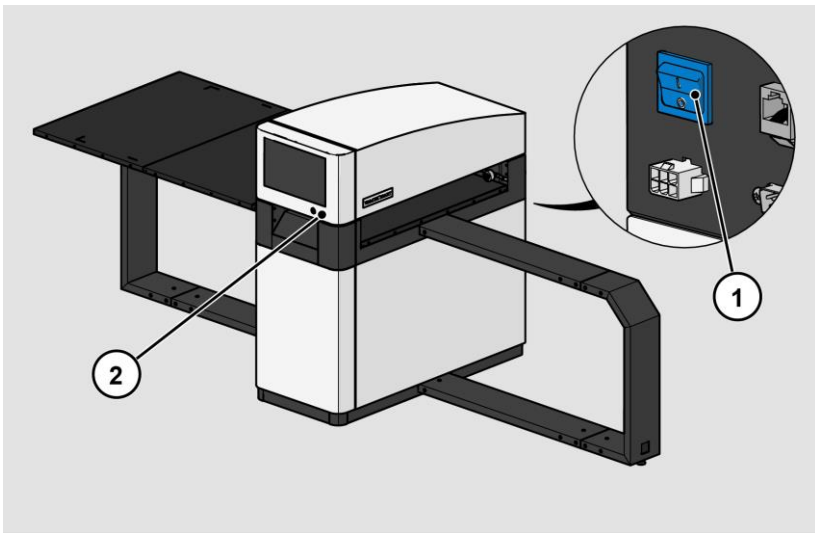

To switch off the scanner using a hard shutdown, proceed as follows:

- Press and hold the power button for longer than four seconds.

The power supply to the scanner is immediately interrupted.

The power button is illuminated in green.

- Press the MAIN SWITCH (1) in the "0" position.

## Perform Setup

### Change the Menu Language

To change the menu language, proceed as follows:

- Tap the LANGUAGE (1) button to see all available languages.

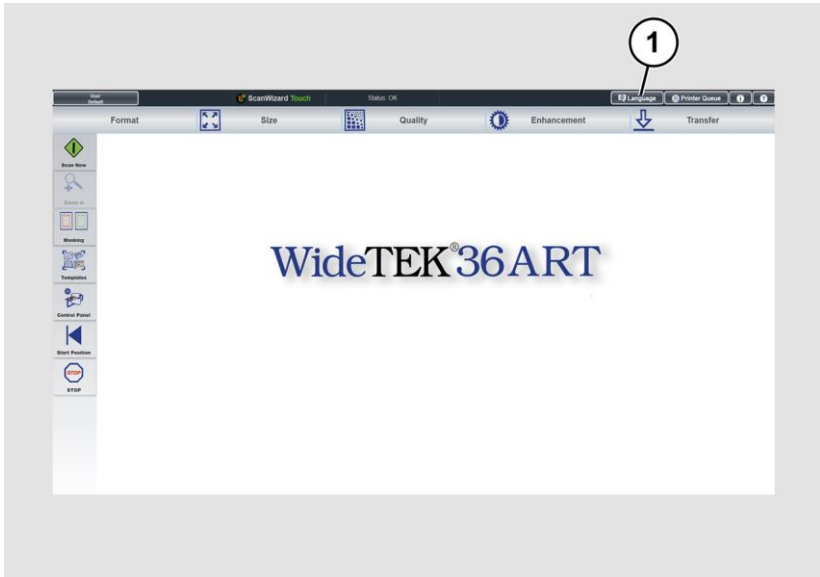

A window for selecting the language appears.

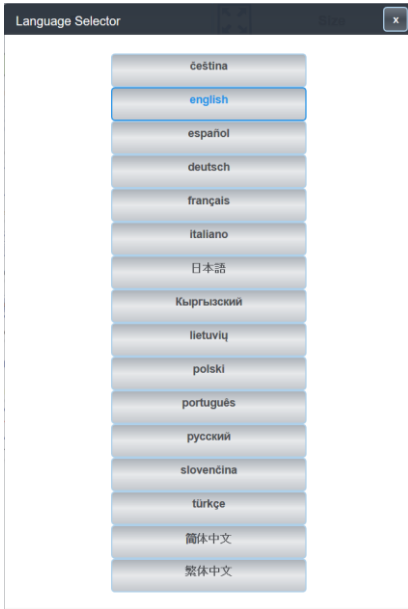

➤ Tap the desired language.

The window for selecting the language is closed. The "Start screen" is displayed.



## Inserting and Aligning the Scan Table

The scan table of the WideTEK 36ART, which holds the objects to be scanned, can be inserted and moved on the scanner by hand.

The scan table rests on the runways and the start position is on the left side.

The right side of the scan table goes in first and is identified by two additional white lines across the shorter edge of the table.

- Place the scan table on the table holders with the longest distance to the table's edge from the white corner markers going in first.
- When the scan table has been placed on the runway, make sure that it is flush with the right side of the scanner stand.
- Make sure the table is not skewed by moving the left end front and back until the right side is flush and straight with respect to the stand.
- To see if it is straight, stand in front of the scanner at the right side and look at how the top edge of the scan table runs alongside the right side of the scanner.

The only physical connection of the table to the scanner are the transport drums and the four pressure rollers. They move the table with limited friction, which is a security feature. The four pressure wheels can be adjusted by unscrewing the center bolt with the SW4 Allen wrench. The pressure wheels should apply a fair amount of pressure to insure friction and should not be freewheeling in any position. There is also no position switch which would tell the scanner where the start position is. The start position is the position the scanner table is in when a scan command is invoked. If the scan table reaches its end, or if the scan is interrupted, press the "START POSITION" button to return the table back to the start position.

## Placing an Object to be Scanned on the Scan Table

- Place the object to be scanned on the table so that it is below the red laser lines.

Depending on the size of the material to be scanned, either both laser lines should be fully on the object or if the object is smaller, one laser line should be fully on the object and the other laser line must be fully off the object. The laser lines should not be partially on an edge of the object but rather either both fully on the object or one fully on and one fully off.

Scanning starts at the white edge lines so the object must be placed inside these lines but it can be placed lower than the lines, as required.

- ⓘ Ensure that the weight of the original to be scanned does not exceed 10 kg / 22 lbs..

The default scan length is 20 inches from the edge lines. This can be adjusted in the software and raised in increments of 10 inches up to the maximum scan length of 60 inches, 87.6 inches with optional scan table extension.

## Adjusting the Camera Position







- In ScanWizard, tap on the CONTROL PANEL button (1).



➤ The WideTEK 36ART Control Panel window appears.



### Camera Position Control

Button	Name
	UP END
	UP
	STOP
	DOWN
	DOWN END
	BASE POSITION

1. Drive the camera to the base position.
2. Drive the camera up using the ▲ button until the right laser focus position is found.
3. Drive the camera up until the right camera position is found.

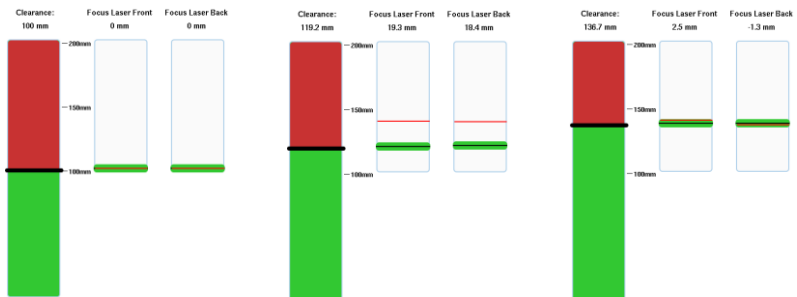

1. Camera height in base position

2. Laser focus in right position

3. Camera height in correct position

**Auto Focus / Fixed Focus Usage Flags**





Button	Name
	AUTO FOCUS / FIXED FOCUS

If both focus settings are set to AUTO FOCUS, the resulting image is stitched based on the height measurement of both lasers. This is the default setting.

If one of the focus settings on the control panel is set to AUTO FOCUS and the other one is set to FIXED FOCUS, the image will be stitched based on the height measurement of the AUTO FOCUS laser alone. The height of the target below the other stitching line is assumed to be the same as the height below the AUTO FOCUS laser. This can be useful to scan small targets that aren't large enough to be measured with both lasers.

If both focus settings on the control panel are set to FIXED FOCUS, only a small area around the stitching line will be matched to eliminate stitching artifacts. This can be useful to scan targets that cause stitching artifacts when using the default setting.

**Table Position Control**

Button	Name
	LAST SCAN START POSITION
	LEFT
	STOP
	RIGHT

- Finally drive, or move, the scan table back to its start position.
- Change to the ScanWizard application to select scan parameters and to start a scan.

## Scanning and Watching the Object Move Through the Scanner

When the scan has been started, the operator can observe how the object moves under the illumination line and the image is scanned line by line as the object moves through the scanner.

When the object has passed through the illumination line, the scan is complete and can be stopped by pressing the stop button.

In order to avoid unnecessary adjustments to the scan table, it is recommended that you observe the object you are scanning as it passes through the scanner and clears the illumination line, stopping the scan when it has cleared.

## Preparing Whitebalance



- In ScanWizard, tap on the CONTROL PANEL button (1).
- The WideTEK 36ART Control Panel window appears.

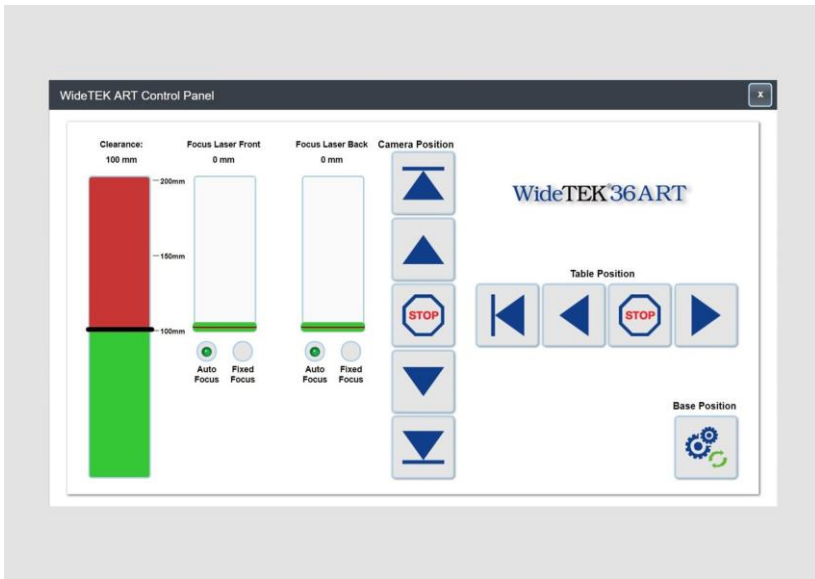



- Drive the camera in its start position, using the BASE POSITION button (1).

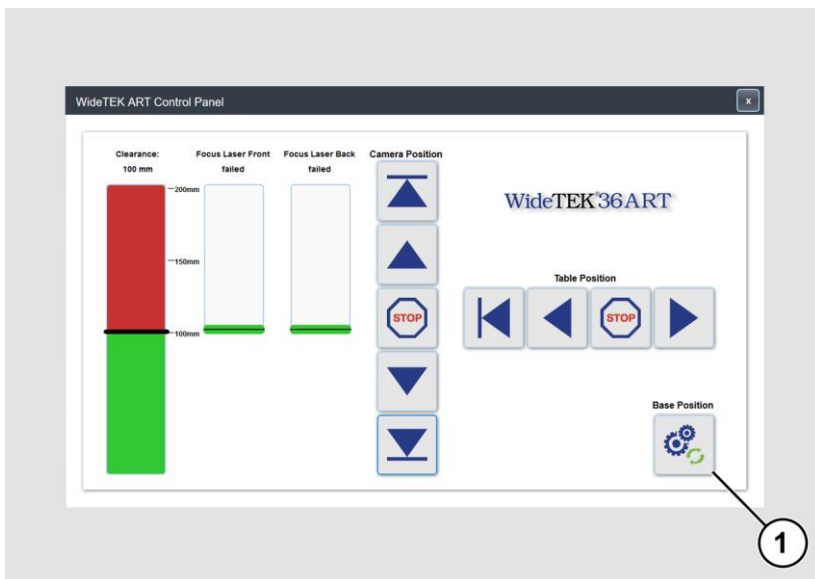

- Drive the scan table in its start position, using the ◀ and ▶ buttons, so that the top edge of the scan table runs alongside the right side of the scanner.
- Place the white balance target in a straight horizontal position on the table, so that the top edges of the target lay below the beginning of the transport drums.
- Wipe over the target carefully with your hand to ensure a flat surface.
- After the White Reference Target WT36C-Z-01-A has been placed in front of the pressure rollers, manually move the scanning table carefully to the point where the middle of the black line is flush to the left side of the scanner.
  - ✓ The image below shows the white balance target in its correct start position.

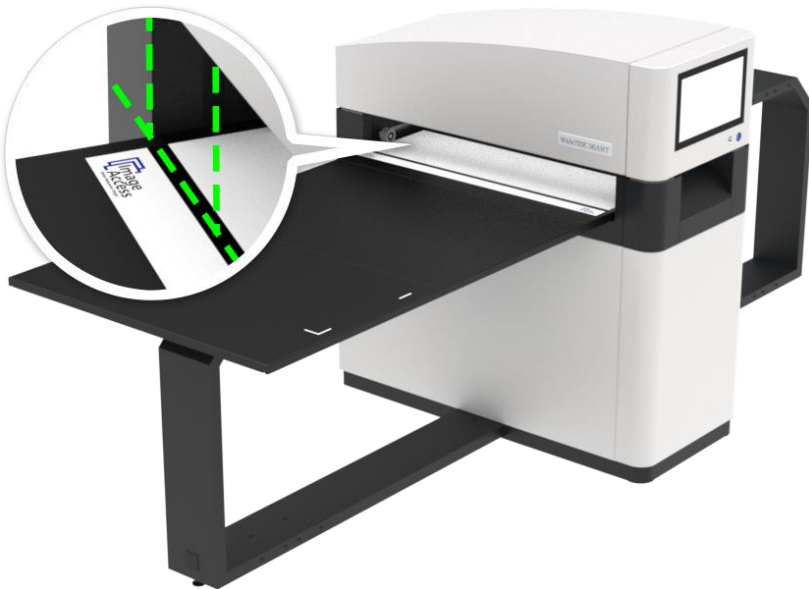

The same procedure applies to adjusting the stitching using the Stitching Target WT36C-Z-02-A. The stitching can only be adjusted through a web browser, running on a PC in the Power User level.

## Activate the Setup Menu

To activate the setup menu, you have to log in on the scanner. Proceed as follows:

- Tap the USER DEFAULT button (1).



The User Login window appears.

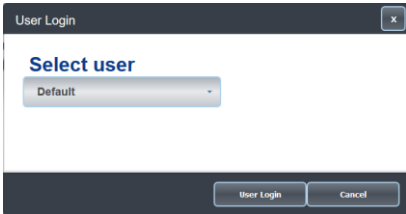

➤ In the User Login window, select the user Poweruser.

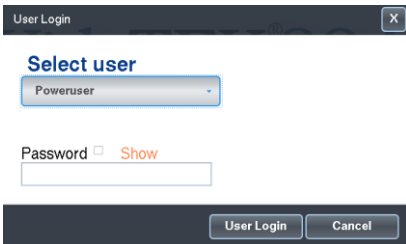

➤ To enter the credentials, tap with your finger on the "Password" input field.

➤ Activate the "Show" box to see the password while entering it.

The screen keyboard is displayed.

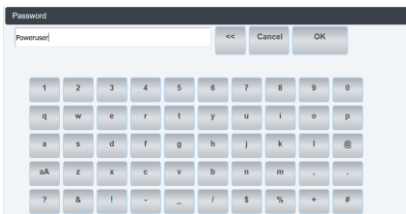

➤ Enter the word "Poweruser" in the field "Password".

➤ Please note that the input is case sensitive.

➤ To complete the password entry, press OK.

The User Login window appears.

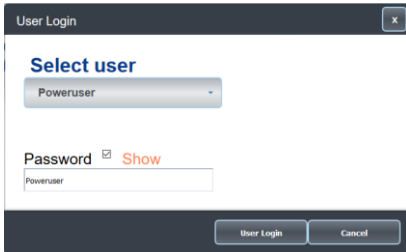

- To complete the log in, press USER LOGIN.  
The ScanWizard window appears.

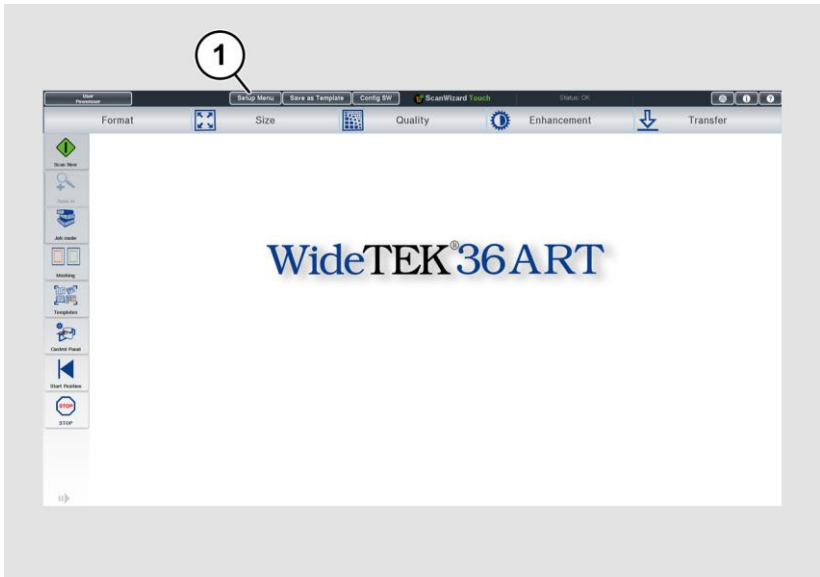

- To start the Setup Menu, press the button SETUP MENU (1).

The "Setup Menu" screen is displayed.

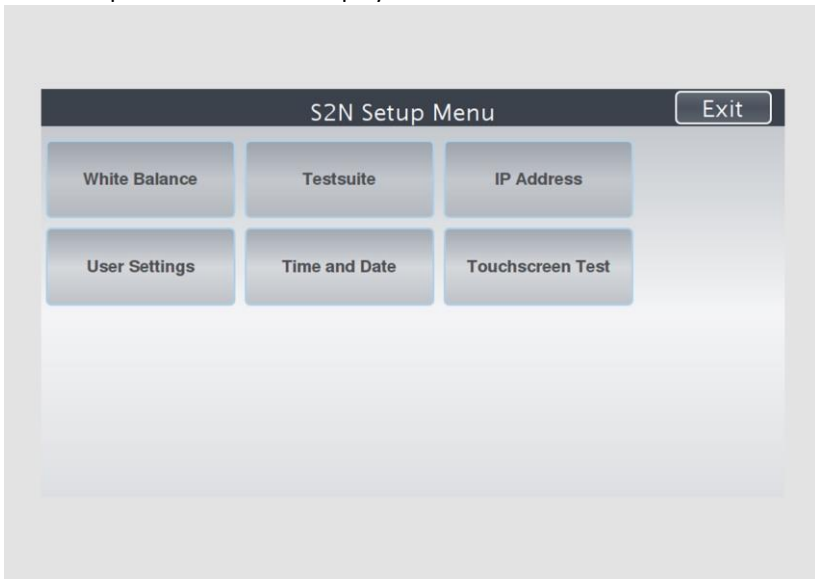

White Balance:            Display the "White Balance" submenu

Testsuite:                Display the "Testsuite" submenu

IP Address:               Display the "IP Address" submenu

User Settings:            Display the "User Settings" submenu

Time and Date:           Display the "Time and Date" submenu

➤ To select a submenu from the "S2N Setup menu" screen, tap with your finger on the button of the screen.

## Perform White Balance

- On the "Setup Menu" screen, tap on WHITE BALANCE (1).

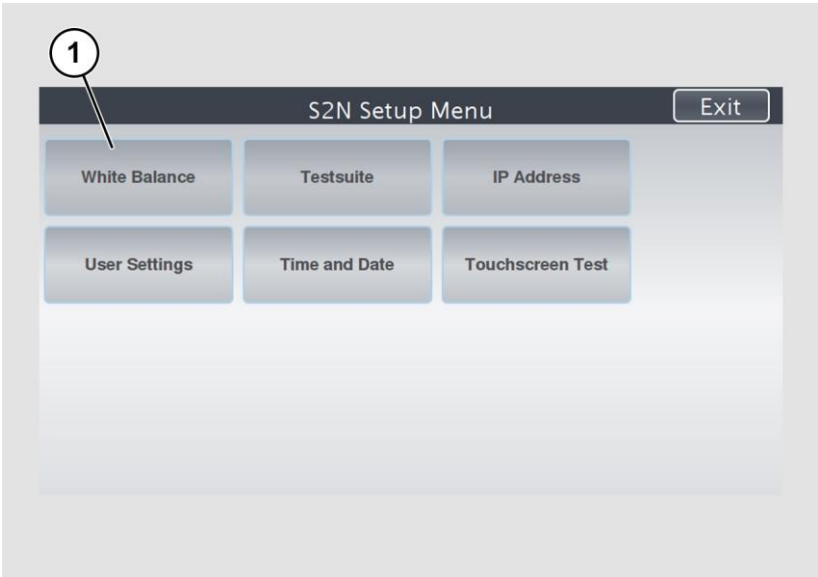

The "White Balance" screen is displayed.

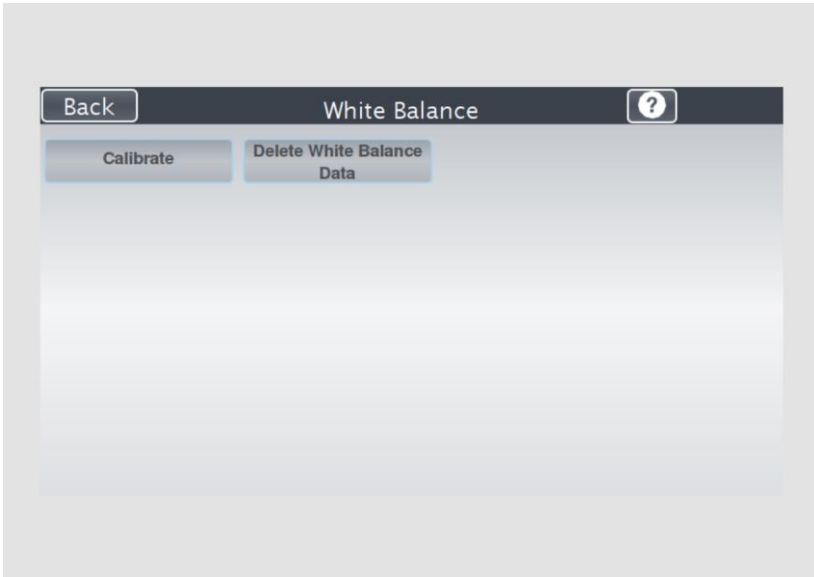

Calibrate:                      Start white balance  
Delete White                    Delete existing white balance data  
Balance Data:

The white balance is used to ensure the quality of the scan results. The white balance will be carried out using a test target. The test target is marked as follows:

- WT36C-Z-01-A for WideTEK® 36



### ATTENTION!

Impairment of the scan quality can occur if an improper test target for the white balance is used.

- Make sure that the test target is free from wrinkles, discolorations, cracks or other damage.
- Store the test target for the white balance in a safe place protected from daylight.

To perform the white balance, proceed as follows:

- Check the position of the supplied test target (1) on the scan table as illustrated below (2).

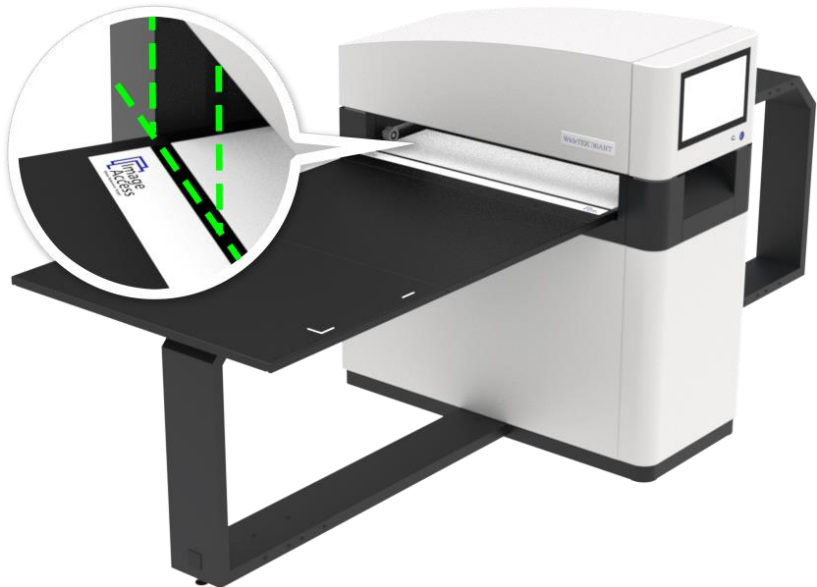

To perform the white balance, proceed as follows:

- Tap on CALIBRATE (1).



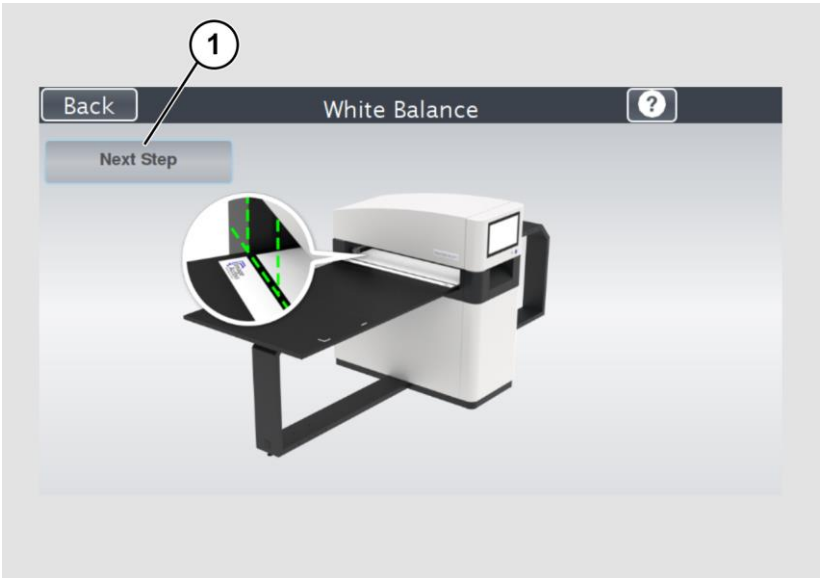

- Tap on NEXT STEP (1).

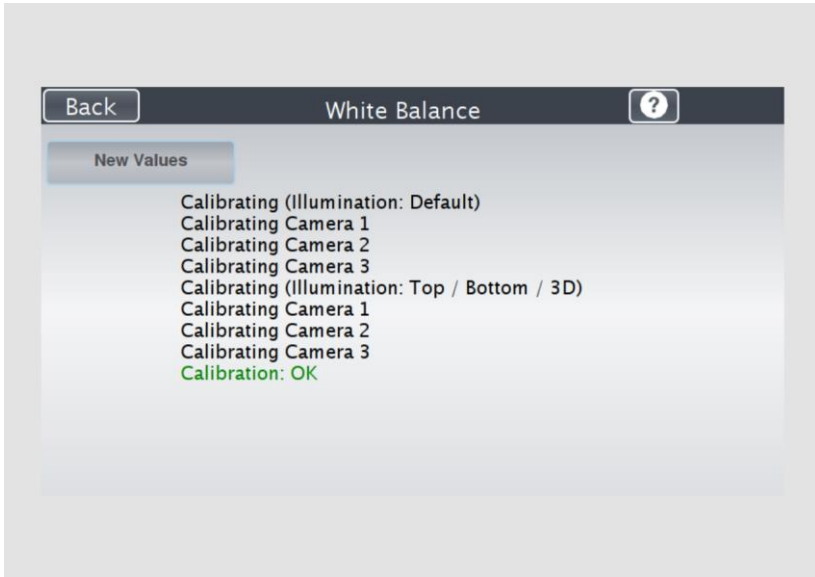

The white balance starts and the calibration is performed. During the white balance, a rotating icon appears. The test target is transported forward and returned. The entire white balance sequence takes about 50 seconds.

Then, the white balance result is displayed as shown in the example below.



 On an error-free white balance calibration, the result is displayed in green.

An incorrect result is displayed in red. If this is the case, repeat the white balance calibration again.

- To perform the white balance again, tap NEW VALUES (2).
- To return to the previous submenu, tap BACK (1).

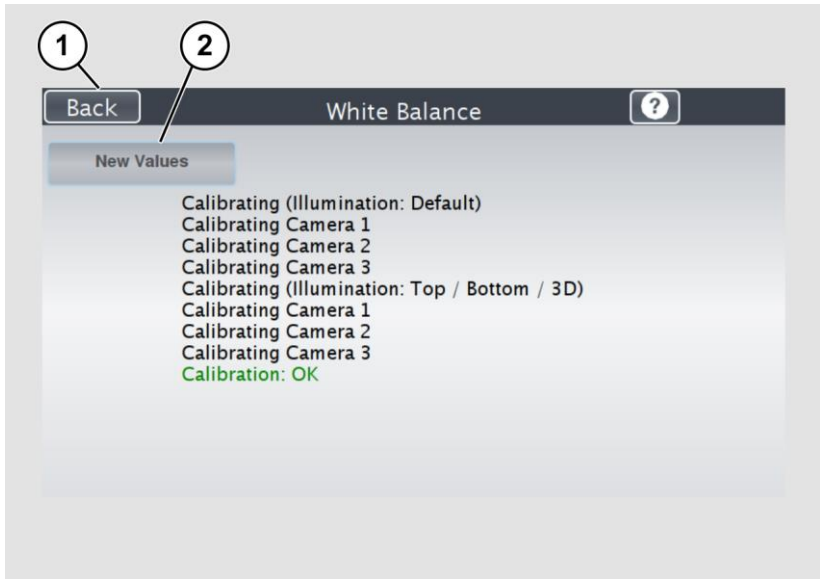

- To delete the stored data of the white balance calibration, tap DELETE WHITE BALANCE DATA (2).
- After deleting the stored data, run the white balance again, as described.
- If problems arise during the white balance calibration, contact Image Access technical support, see section *Technical Support* starting at page 9.
- To return to the previous submenu, tap BACK (1).

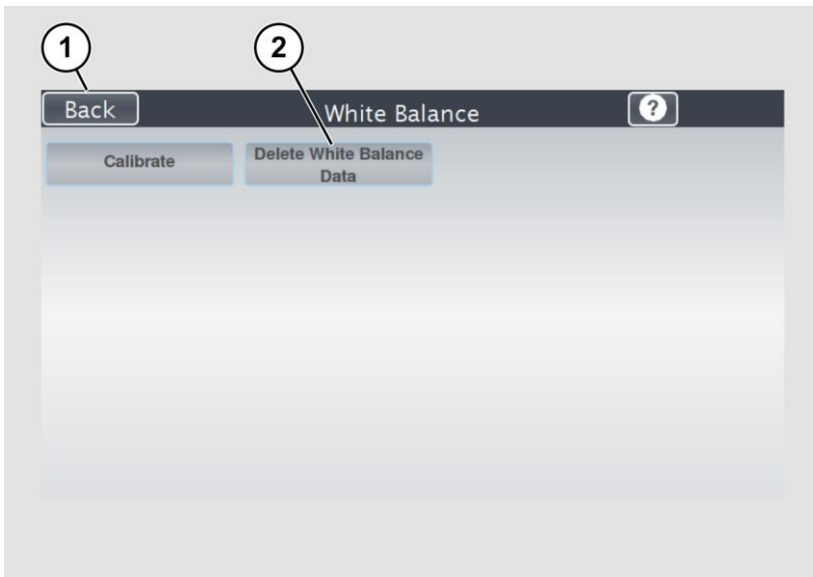

After a successful white balance, proceed as follows:

- Remove the test target.
- Store the test target in a place which is protected from daylight.
- Ensure that the test target is not damaged, bent or soiled.

## Assign the IP Address

### Manually Assign the IP Address

To manually assign the IP address, proceed as follows:

- On the "Setup Menu" screen, tap on IP Address (1).

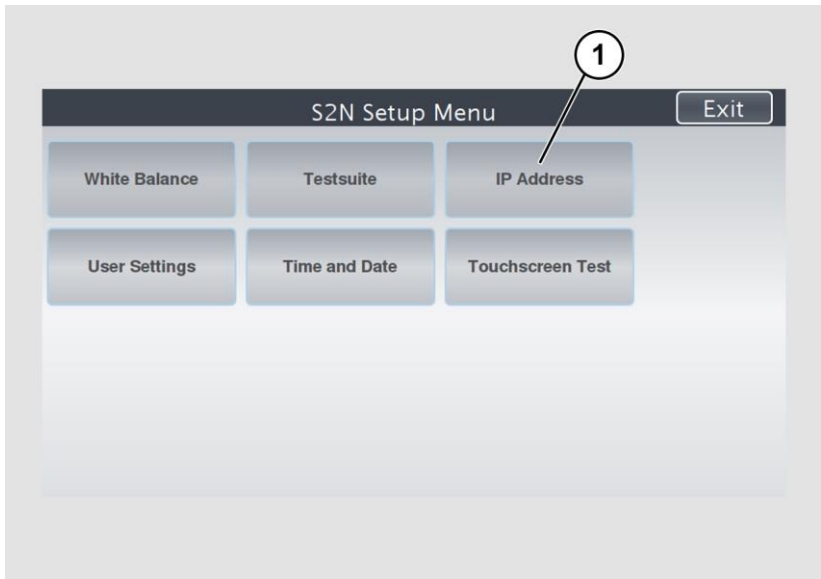

The "IP Address" screen is displayed.

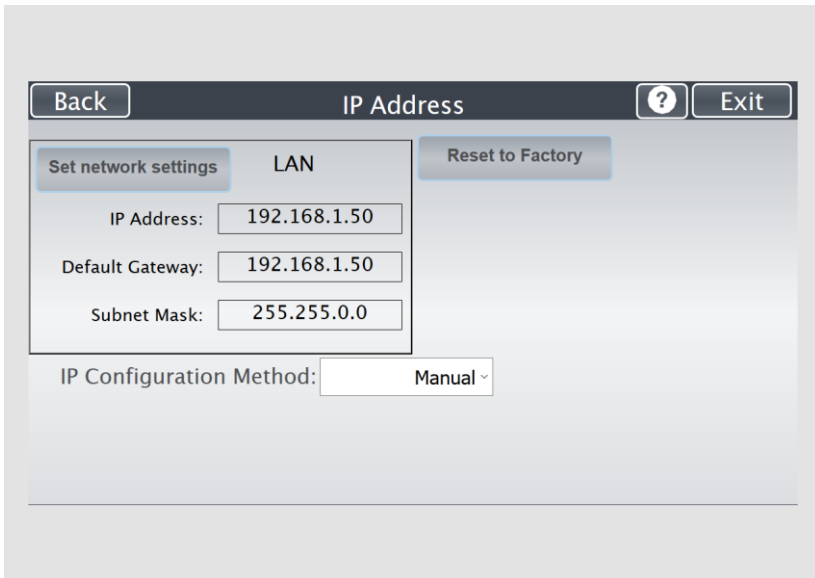

- |                         |  |
|-------------------------|--|
| Set network settings:   | Accept the network settings provided           |
| Reset to Factory:       | Reset to factory settings                      |
| IP Address:             | Input field for the IP address                 |
| Subnet Mask:            | Input field for data on the subnet mask        |
| Gateway:                | Input field for the gateway address            |
| IP Configuration Method | Assign an IP address manually or automatically |
| Manual/DHCP:            |  |



- Tap the "IP Address" (1) field.

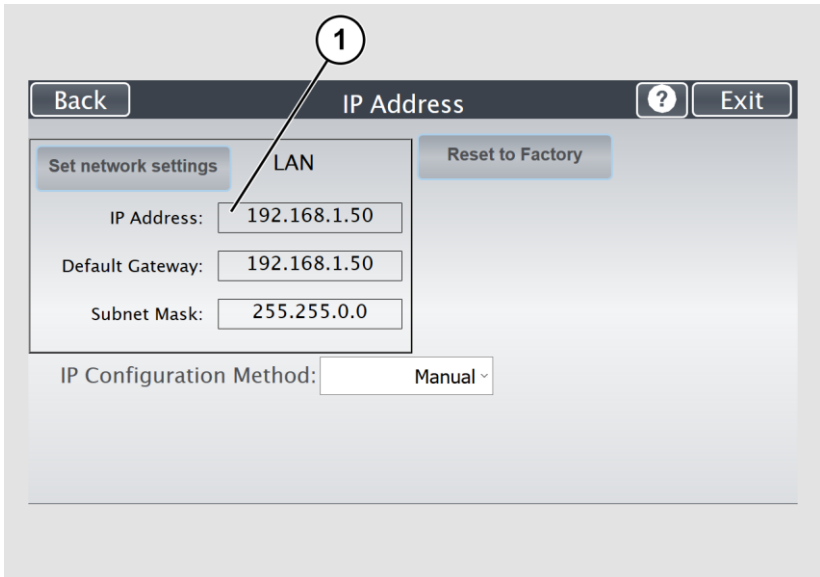

The screenshot displays the "IP Address" configuration screen. At the top, there is a "Back" button on the left, the title "IP Address" in the center, and a help icon (?) and "Exit" button on the right. Below the title bar, there are three main sections: "Set network settings" (with a sub-label "LAN"), "Reset to Factory", and "IP Configuration Method". The "Set network settings" section contains three input fields: "IP Address:" with the value "192.168.1.50", "Default Gateway:" with the value "192.168.1.50", and "Subnet Mask:" with the value "255.255.0.0". A callout bubble with the number "1" points to the "IP Address:" field. The "IP Configuration Method:" is set to "Manual" with a dropdown arrow.

The "IP Address" window is displayed.

- Enter the IP address (1).

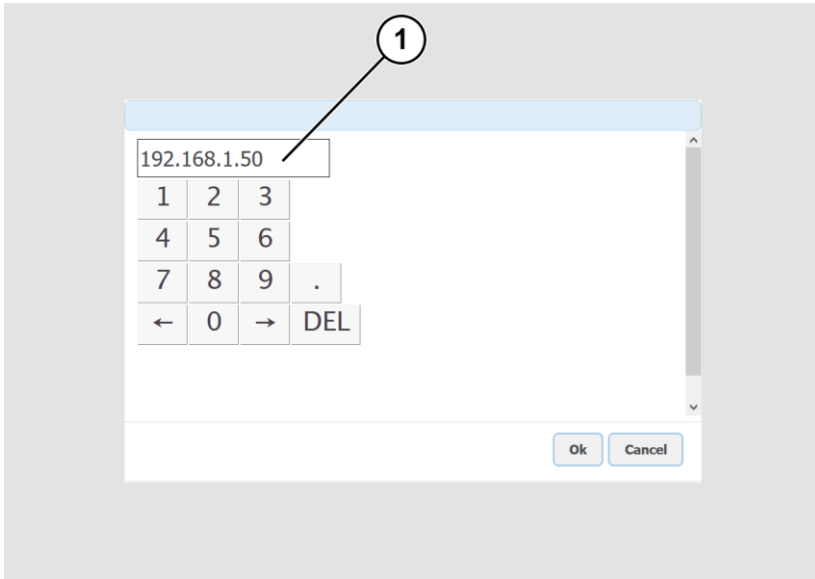

- To delete a digit, move the cursor to the right, behind the digit to be deleted and tap DEL (1).

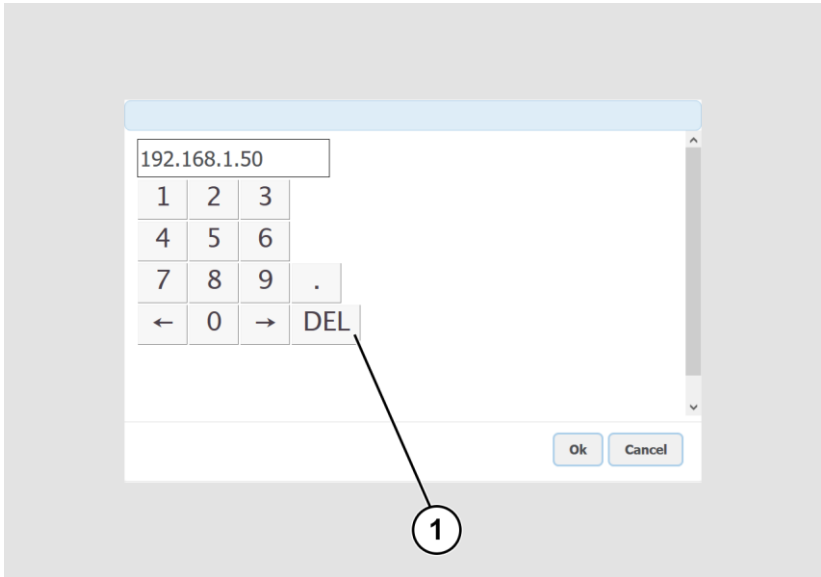

The arrow keys left (1) and right (2) next to the number "0" move the cursor within the chosen row.

- To complete the entry, press OK (3).
- Perform the settings for gateway and subnet mask in the same way.

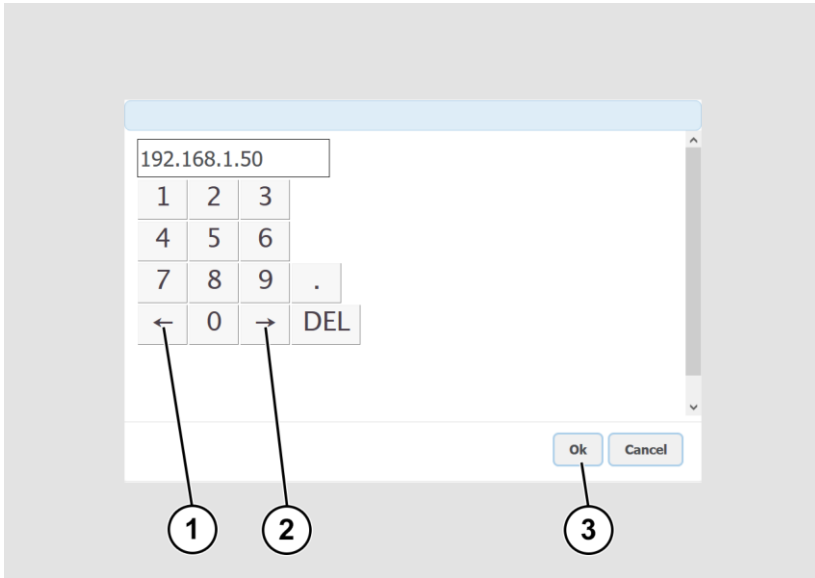

- To save the network settings, tap SET NETWORK SETTINGS (2).
- To return to the previous submenu, tap BACK (1).

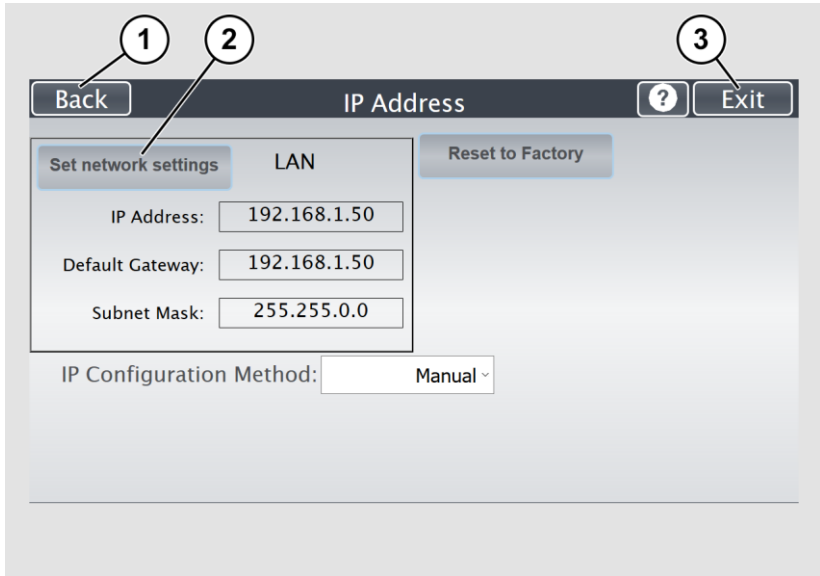

### Automatically Assign the IP Address

To automatically assign the IP address, proceed as follows:

- On the "Setup Menu" screen, tap on IP Address (1).

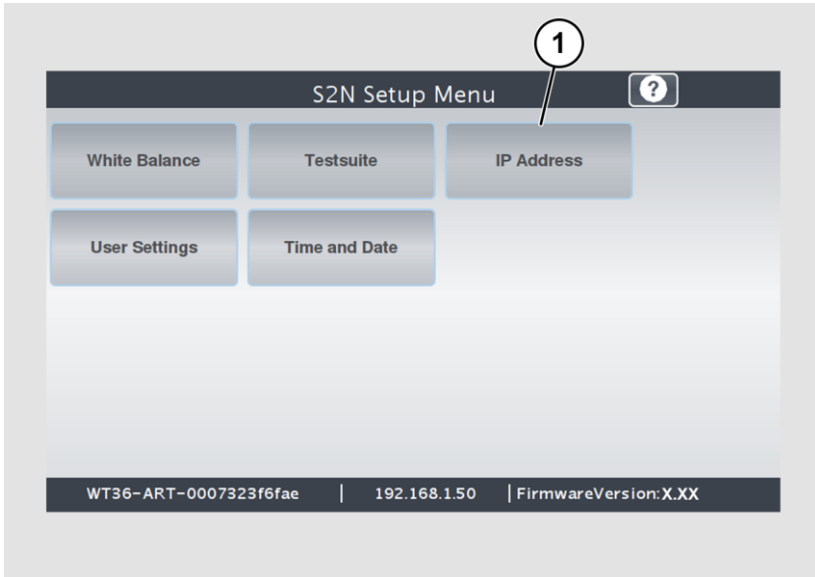

- In the selection menu "IP Configuration Method", select the "DHCP" (2) entry.
- To return to the previous submenu, tap BACK (1).

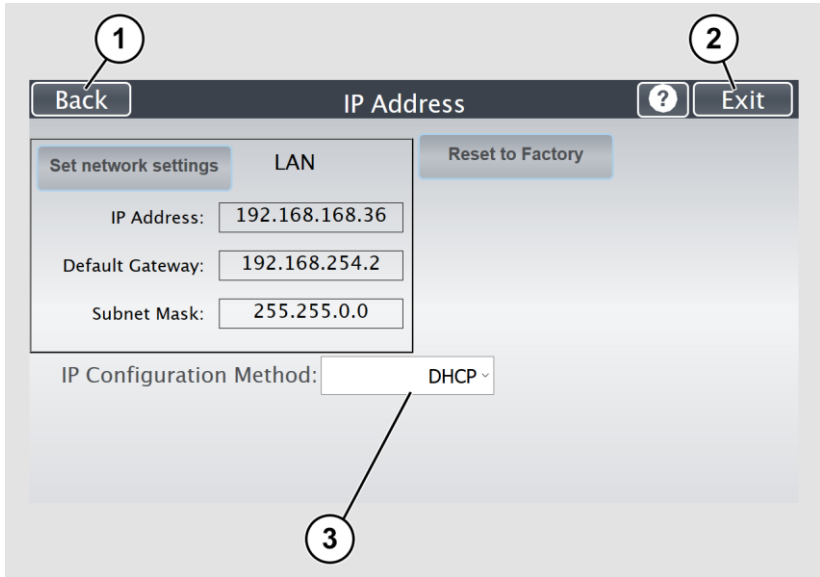

## Modify User Settings

- On the "Setup Menu" screen, tap on USER SETTINGS (1).

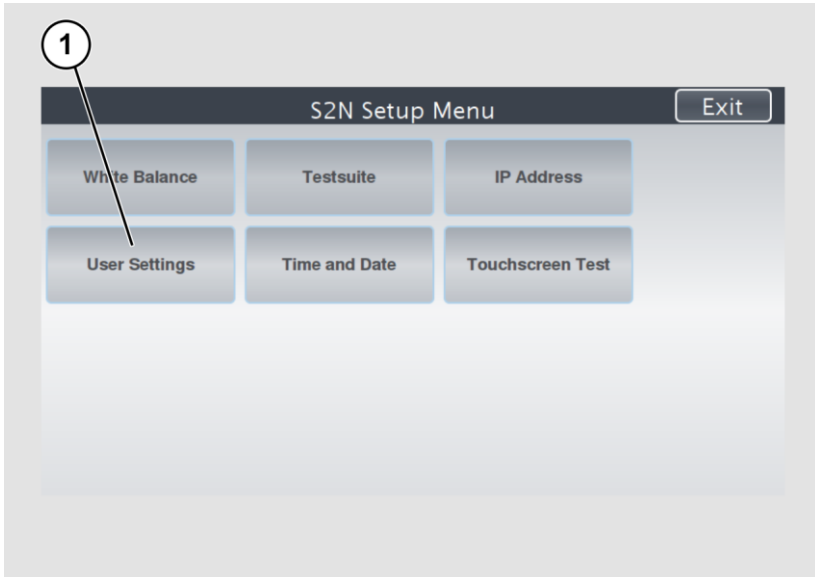



The "User Settings" screen is displayed.

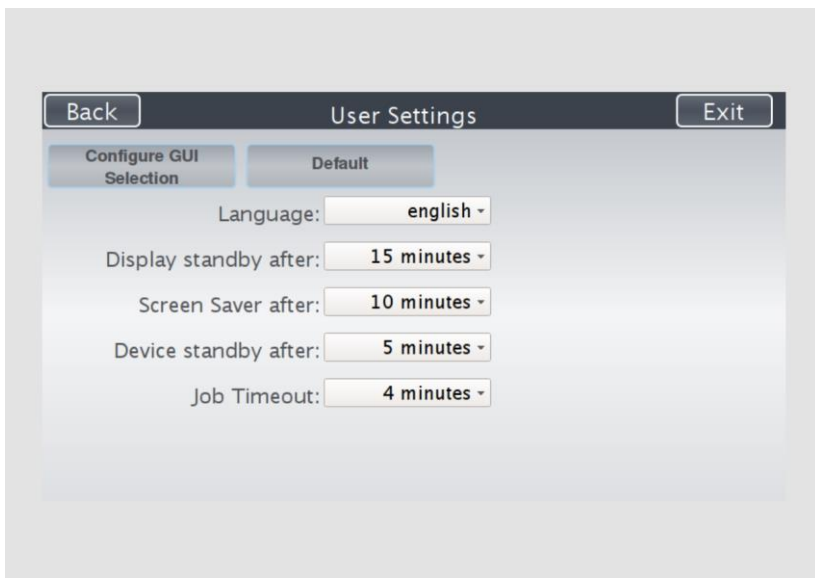

- |                        |  |
|------------------------|--|
| Default:               | The scanner default settings will be established again   |
| Language:              | Select language  |
| Display standby after: | Define the period of inactivity, until an optional external monitor and the touchscreen switch to the standby mode |
| Screen Saver after:    | The period of inactivity is defined until the screen saver is activated  |
| Device standby after:  | The period of inactivity is defined until the scanner goes into standby mode                                       |

### Select Language

To select the language, proceed as follows:

- Tap the on the selection arrow of the selection menu "Language" to display the list of languages.
- Tap the desired language (2).
- To return to the previous submenu, tap BACK (1).

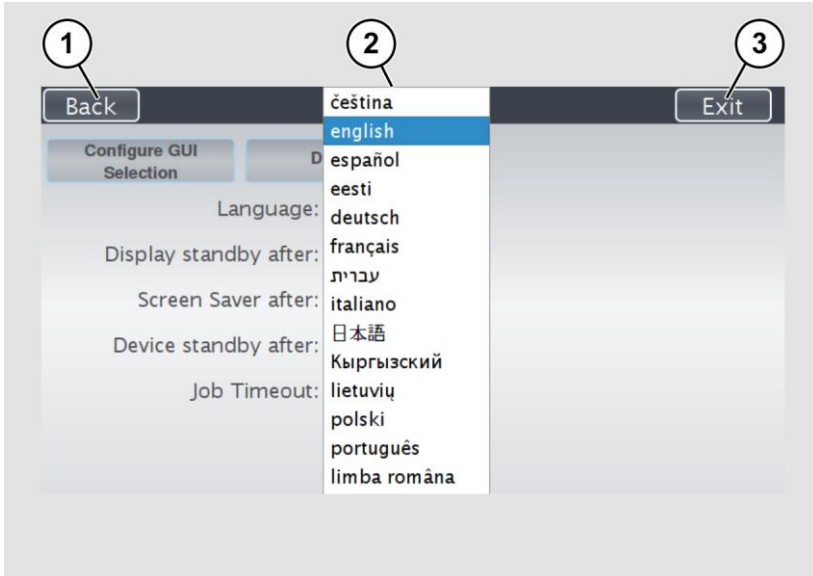

### Set Standby Times

To set the standby times, proceed as follows:

- Tap the selection arrow of the selection menu.
- Tap on the desired entry (2).
- Perform the settings for the screen saver and the device standby in the same way.
- To return to the previous submenu, tap BACK (1).
- To return to the "Start screen", tap EXIT (3).

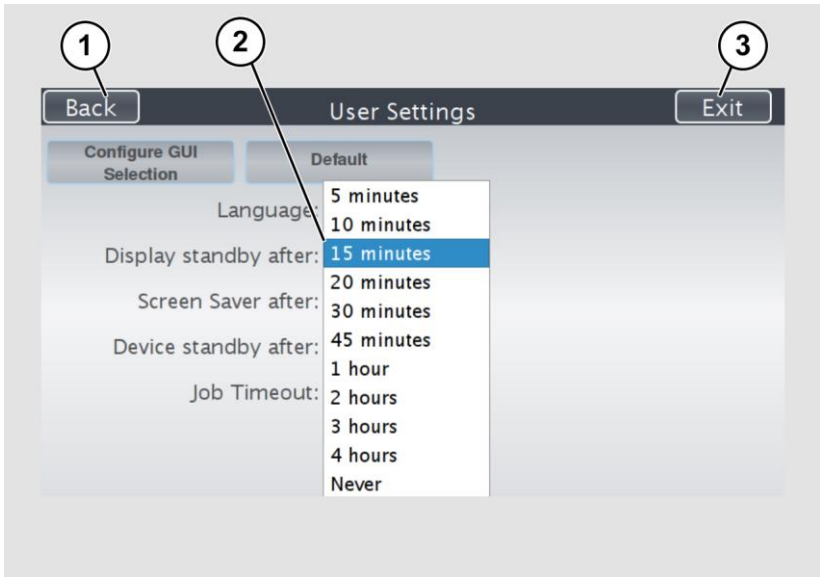

## Set the Time and Date

- On the "Setup Menu" screen, tap on TIME and DATE (1).

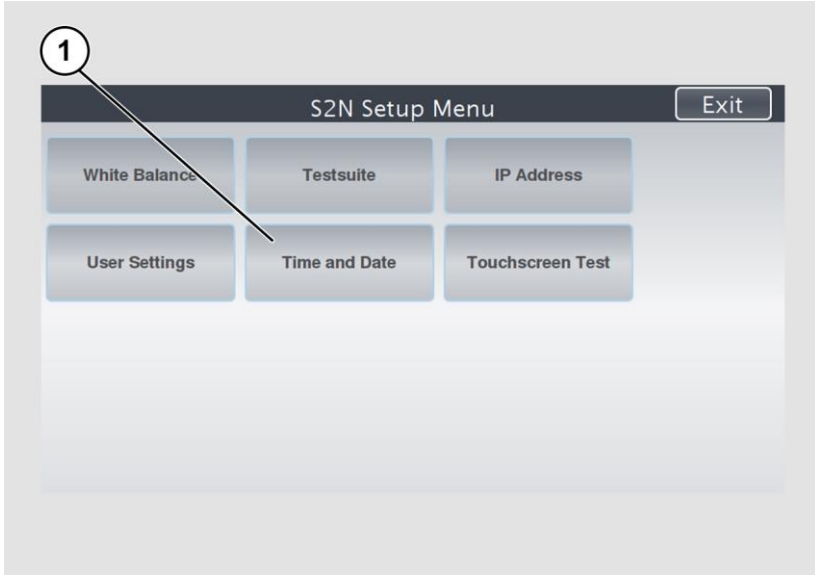

The screen "Time and Date" appears.

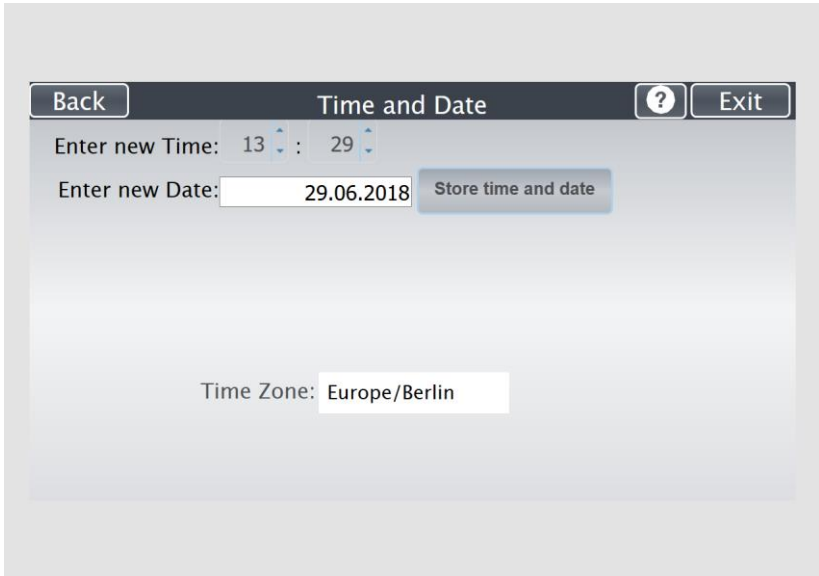

Back Time and Date ? Exit

Enter new Time: 13 : 29

Enter new Date: 29.06.2018 Store time and date

Time Zone: Europe/Berlin

- |                      |   |
|----------------------|---|
| Enter new time:      | Enter hours and minutes with the arrow keys |
| Enter new date:      | Open a calendar to set the date             |
| Store time and date: | Accept the set values                       |
| Time Zone:           | Select a time zone                          |

To set the time, proceed as follows:

- Tap the "Enter new time" field.
- To set the time later, tap the up arrow (2).
- To set the time earlier, tap the down arrow (2).
- To save the modified time, click STORE TIME AND DATE (3).
- To return to the previous submenu, tap BACK (1).

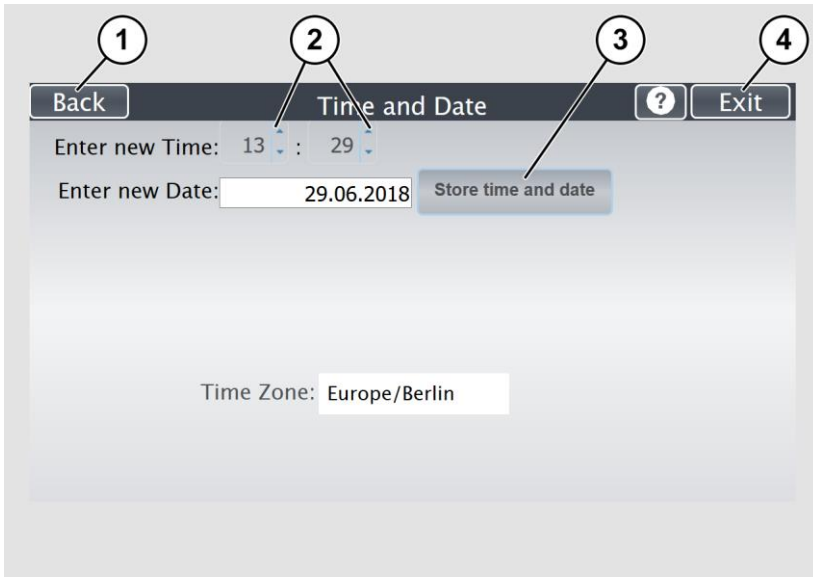

To set the date, proceed as follows:

- Tap the "Enter new date" field.

A calendar (3) is displayed.

- Select the appropriate date in the calendar (3).
- To set the month and year, tap the arrow keys (2, 4) at the top of the calendar.
- To set the day, tap the corresponding day in the calendar.
- To save the date, click STORE TIME AND DATE (5).
- To return to the previous submenu, tap BACK (1).

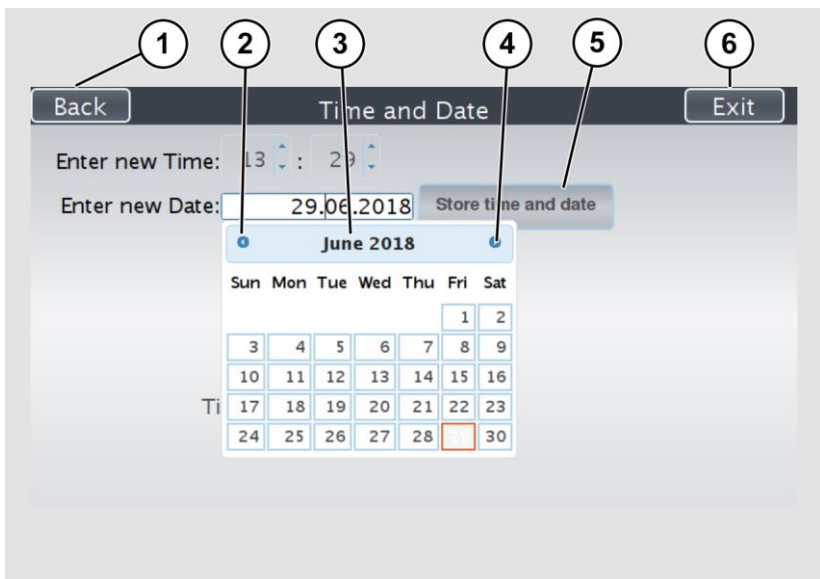

## Perform Setup

- To select the time zone, tap the selection arrow (3).  
A selection list with available time zones is displayed.
- Select the appropriate time zone.
- To save the time zone, click STORE TIME AND DATE (2).
- To return to the previous submenu, tap BACK (1).

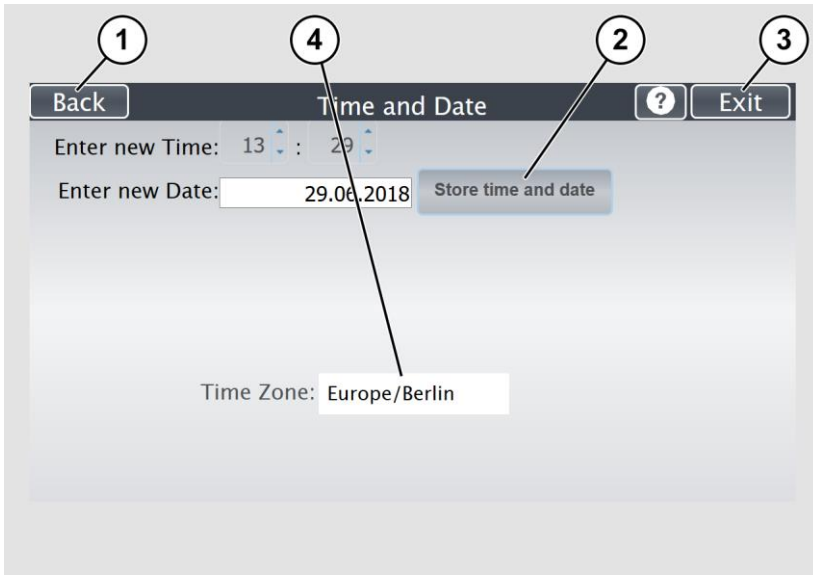



## Perform Test Suite

- On the "Setup Menu" screen, tap on TESTSUITE (1).

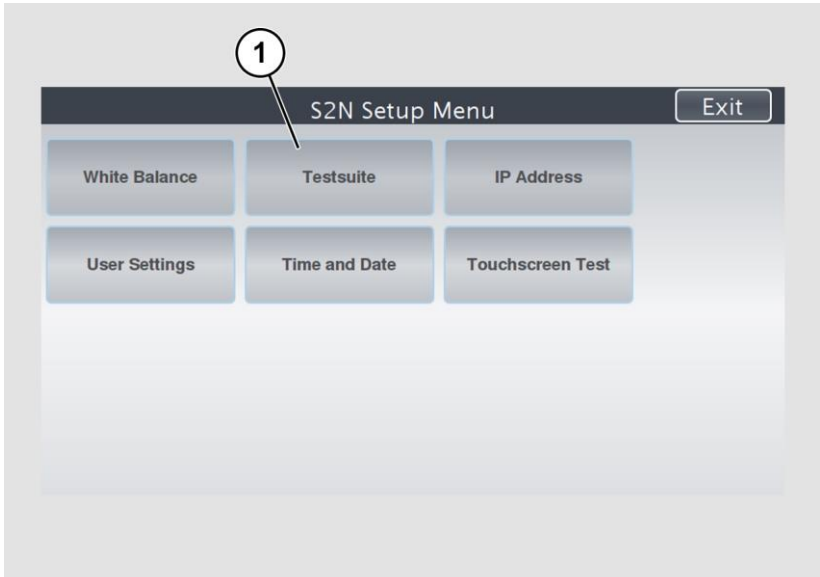

The "Testsuite" screen is displayed.

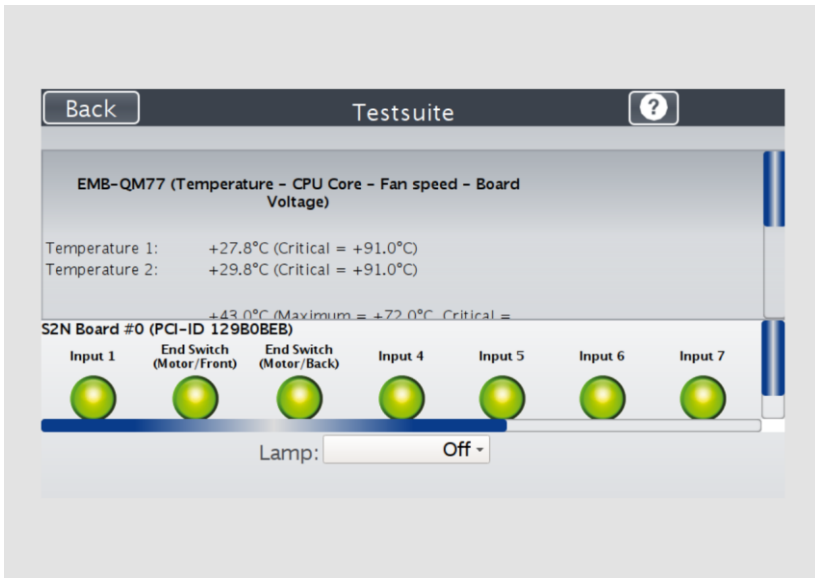

Information about the mainboard:

Display the current values for: Temperature of PCB and CPU cores, fan speed, PCB voltages

Information about the inputs:

Inputs will always appear green

Information on end position switches:

When the end position switches are activated, the display changes from green to red, for as long as the switches are activated

Information about LED lamps and lasers:

Check function: Lamp 1, Lamp 2, Laser Check, Off

### Test the LED Lamps Functionality

- To check whether both LED lamps working properly, select from the "Lamp" menu the entry "Lamp 1" and "Lamp 2" one after the other (2). The LED lamps are illuminated.
- To return to the previous submenu, tap BACK (1).

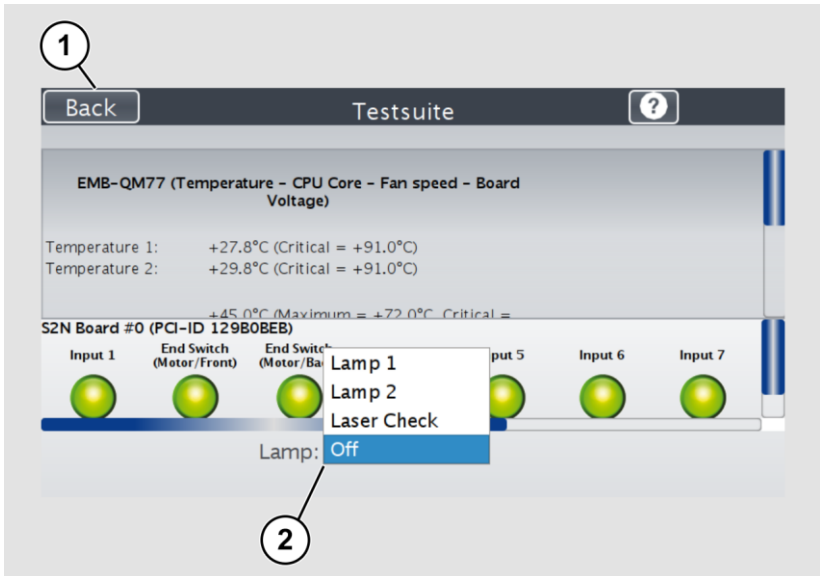

### Test the Laser Functionality

- To check whether the LED lamps work properly, select from the "Lamp" menu the entry "Laser check" (2). The Lasers are illuminated.
- To return to the previous submenu, tap BACK (1).

## Perform Touchscreen Test

To check the functionality of the touchscreen when touched, proceed as follows:

- On the "Setup Menu" screen tap the TOUCHSCREEN TEST (1) button.

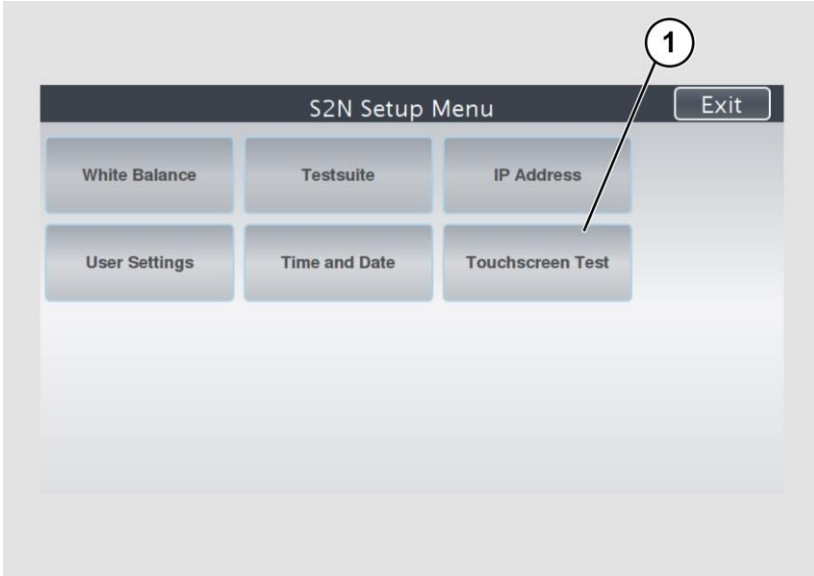

The "Touchscreen Test" screen is displayed.

- To perform the "Touchscreen Test" tap with your finger on the corresponding screen (3).

The crosshairs must occupy the same position as the finger.

- To end the "Touchscreen Test", tap the STOP TOUCHSCREEN TEST (1) button.

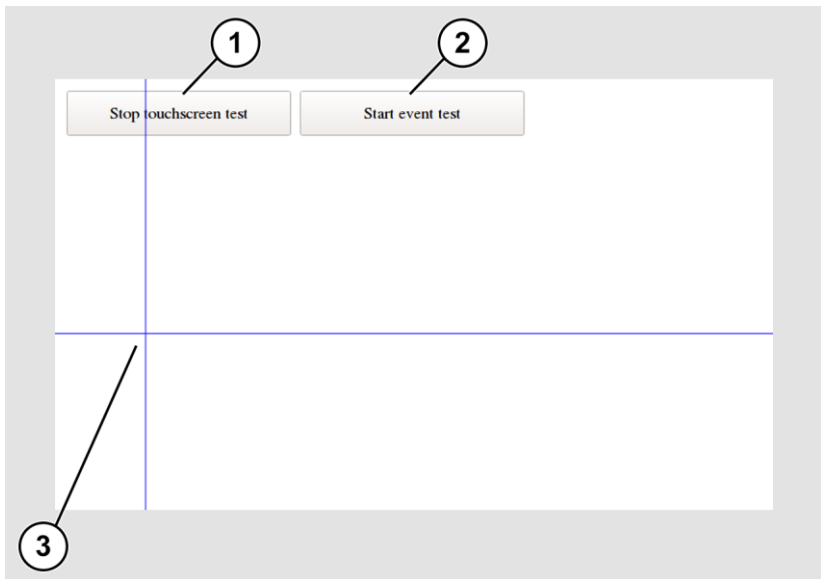

- Tap the START EVENT TEST (2) button.

The "Event Test" screen is displayed.

The X button (3) cancels the test and returns to the start screen "Touchscreen Test".

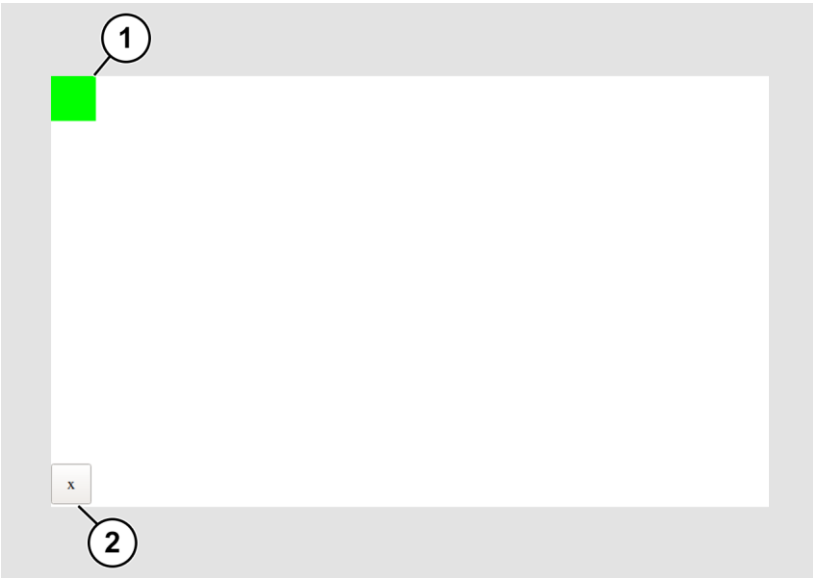

- Hold the upper left blinking green rectangle (1) with your finger.
- Swipe your finger from top left to top right over the touchscreen.

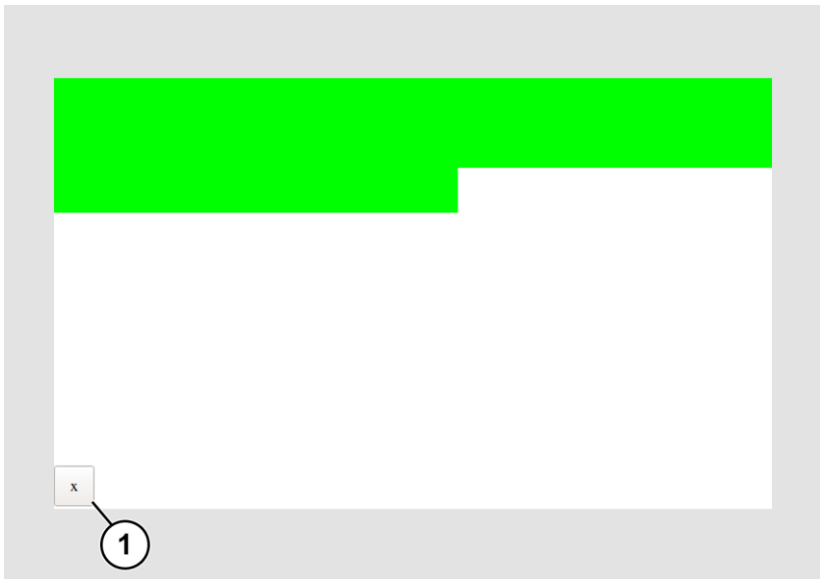

Green rectangles are drawn step by step.

These rectangles mark the area where the "Event Test" has detected the motion events.

- As soon as you arrive at the top right, move down one line and then move to the left again.
- Continue with this procedure until you have reached the lower right edge of the screen.

This test can be aborted at any time by pressing the X (1) button.

If the entire screen is green, the test ends automatically.

The start screen of the "Touchscreen Test" appears.

The "Start screen" is displayed.

## Recovery

### Hard Disk / Solid State Disk Software Failure

The file system and the Linux operating system of a Scan2Net scanner are very robust and forgiving. The file system has the ability to repair itself, even if the system loses power during a disk write operation, a condition which will almost certainly corrupt any Windows, Android or MAC OS based computer.

Nevertheless, under certain circumstances it could happen that the Scan2Net Linux software on the HD/SSD becomes corrupt. Unexpected power failures, hard power off cycles via the main power switch without a previously controlled shut down and other unexpected terminations of the operating system may cause this kind type of failure. Also, any uncontrolled interrupt of a firmware update procedure or other functions which involve writing to the main storage (HD or SSD) are a potential risk to the integrity of the firmware on the HD/SSD. The Scan2Net operating system of every WideTEK® or Bookeye® scanner is Linux based and although it happens very rarely, the Linux operating system can be corrupted like any other operating system; whether it is a Windows, Android, Mac or any other OS.

If the Linux operating system or other parts of the HD/SSD are corrupted, there is still no need to replace the HD/SSD, at least not before the recovery procedure is executed once. This procedure is similar to the procedures necessary to restore a Windows, Android or Apple OS to a previous state.



## Recover the HD/SSD to Factory Default

In a Scan2Net® scanner, an image of the Scan2Net Linux operating system is stored on the Recovery Partition at certain times. The image is generated at the time of manufacturing, and also any time an HD/SSD needed to be replaced.

## Preparations to Recover an HD/SSD



- Make sure that you know the scanner's IP address, subnet and gateway valid for the network or have the network administrator available.
- Login to the Image Access Customer Service Portal at <http://portal.imageaccess.de> and obtain the latest firmware for your device.

Step	Action
1	<p>If still possible, shut down the scanner, either through the touch panel or through the currently used application or by pushing the start button on the scanner's housing.</p> <p>Otherwise, switch off the scanner at its main power switch.</p>

## Recovery Process



Make sure that the following process is not interrupted by a hard shut down or power failures.

If this process is interrupted, a loss of the recovery partition is possible, making it mandatory to physically replace the HD/SSD.





The following process cannot be influenced by the user.

### Recovery Process 1

The recovery procedure is a simple multistage process.

Step	Action
2.1 - Scanner with recovery key	Wait until the scanner has powered down, then plug in the recovery key to the DB9 connector on the rear side of the scanner.
2.2 - Scanner with STOP button	Wait until the scanner has powered down.
3 - All scanners	Make sure that the main power is switched on.
4.1- Scanners with recovery key	Power up the scanner via the POWER button.
4.2 - Scanners with STOP button	Press and hold the red STOP button (1) before switching ON. Power up the scanner via the POWER button. Important: The red STOP button (1) must be pressed and then held until the red button is lit permanently.

Step	Action
5 - All scanners	<p>The recovery procedure starts automatically.</p> <p>It replaces the corrupted content of the Scan2Net Linux partition with the content of the recovery partition.</p> <p>This process takes about 10 - 15 minutes.</p> <p>At the end, it powers down the scanner.</p>
6 - All scanners	Wait until the scanner has powered down.
7 - All scanners	Switch it off via the main power switch.
8 - Scanners with recovery key	Remove the recovery key from the connector on the rear side of the scanner.
9 - All scanners	Switch on the scanner via its main power switch.
10 - All scanners	Power up the scanner via the start button.

-  After this procedure is complete, all network credentials are lost. Important: The default IP address is now reset to the factory default 192.168.1.50!
-  To set up your own network configuration, please refer to the chapter Assign the IP Address in this Setup and Instructions manual.

## Recovery Process 2 - Update Scanner Firmware

Step	Action
11	In case the currently installed firmware of the scanner is not the latest version, connect the scanner via a web browser.
12	Select "Setup Device".
13	Login in as "Poweruser" with the user name "Poweruser" and the corresponding password. Default password is "Poweruser".
14	Select "Updates & Uploads".
15	In the section "Update Scanner Firmware", update the scanner with the firmware version you downloaded from the Customer Service Portal.

## Recovery Process 3 - Adjustments

Finally, it is required to perform a few adjustments.

 Note: All scanners require that you at least adjust the White Balance.

- Please refer to the Perform Setup chapter in the Setup & Instructions manual of your scanner for the necessity of further adjustments.

End of recovery process.

## Maintenance

- ⓘ Ensure that no liquids penetrate the device housing.

### Touchscreen

The touchscreen can be cleaned with a microfiber cloth.

Before cleaning the touchscreen, switch the scanner off and set the main power switch to position 0.

### Surfaces

Use a soft, dampened cloth to clean the housing of the scanner.

Recommended is a micro fiber cloth.

### Repair

- ⓘ There are not any parts or components of the WideTEK® scanner which can be repaired by the user.  
All repairs and service works should be done by a trained technician only.

# Technical Specifications

## Scanner Specification

### Optical System

Maximum document size	914 x 1524 mm (36 x 60 inches), optional Scan table extension up to 914 x 2224 mm (36 x 87,6 inches)
Optical resolution	600 × 600 dpi
Pixel dimension	9.3 × 9.3 μm
Sensor type	3 x Tri-color line sensor CCD, encapsulated and dust-proof
Color depth	16 bit grayscale (internal resolution) 48 bit color (internal resolution)
Sensor resolution	67,500 pixels (3 x 22.500)
Scan modes	24 bit color, 8 bit color indexed, 8 bit grayscale, bitonal, enhanced halftone
File formats	Multipage PDF (PDF/A) and TIFF, JPEG, JPEG 2000, PNM, PNG, BMP, TIFF (Raw, G3, G4, LZW, JPEG), AutoCAD DWF, JBIG, DjVu, DICOM, PCX, Postscript, EPS, Raw data

### Illumination System

Light source	Two lamps with white LEDs, integrated optical diffusor
Warm-up time of the lamps	None Max. brightness immediately after switch on
Temperature dependency	None
UV / IR radiation	None

Lifetime of the LEDs	50,000 hours (typically)
----------------------	--------------------------

## Electrical Specifications

### External Power Supply

Input voltage	100–240 Vac
Frequency	47–63 Hz
Output voltage	24 Vdc
Output current	6,25 A
ECO Standard	CEC Level VI

### Scanner

Input voltage	24 Vdc
Input current	Max. 5 A

### Power Consumption

Sleep	≤ 0,5 W
Standby	ca. 5.2 W
Ready to scan	< 50 W
Scanning	< 110 W

## Document Specification

Maximum scan heights	100 mm (4 inches)
Document thickness	200 mm (8 inches) E.g. Canvas up to max. 100 mm in a frame up to 200 mm thickness
Maximum permissible document weight	10 kg (22 lbs.)

## Dimensions and Weight

Scanner outer dimensions with runway (H x W x D)	1380 x 3275 x 1280 mm (54.3 x 128.9 x 50.4 inches)
Scanner outer dimensions without runway (H x W x D)	1380 x 690 x 1280 mm (54.3 x 27.2 x 50.4 inches)
Scan table outer dimensions (W x L)	1000 x 2100 mm (39.4 x 82.7 inches)
Scanner weight	200 kg (440 lbs.)
Scan table weight	22.5 kg (50 lbs.)
Shipping crate dimensions (H x W x D)	1580 x 800 x 1600 mm (63 x 31.5 x 63 inches)
Shipping weight	277 kg (610 lbs.)

## Ambient Conditions

Operation temperature	5 to 40 °C / 40 to 105°F
Storage temperature	0 to 60 °C / 32 to 140°F
Relative humidity	20 to 80% (non-condensing)
Noise level	≤ 35 dB(A) (Operating) ≤ 25 dB(A) (Stand-by)

End of document